

**CONSTRUCTION SERVICES AGREEMENT FOR FORT KING NATIONAL LANDMARK
RESTROOMS**

THIS CONSTRUCTION SERVICES AGREEMENT FOR FORT KING NATIONAL LANDMARK RESTROOMS (Agreement”) is entered into by and between the **CITY OF OCALA**, a Florida municipal corporation (“City”), and **BLACKWATER CONSTRUCTION SERVICES, LLC**, a limited liability company duly organized and authorized to do business in the state of Florida (EIN: 82-2712584) (“Contractor”).

R E C I T A L S :

WHEREAS, on October 3, 2022, City issued an Invitation to Bid (“ITB”) for the provision of construction services related to the building of restrooms at the Fort King National Landmark, ITB No.: CIP/220747 (the “Solicitation”); and

WHEREAS, a total of four (4) firms responded to the Solicitation and, after consideration of price and other evaluation factors set forth in the Solicitation, Blackwater Construction Services, LLC, was chosen as the intended awardee to construct restrooms at the Fort King National Landmark (the “Project”); and

WHEREAS, Contractor certifies that Contractor and its subcontractors are qualified and possess the required licensure and skill to perform the work required for the Project; and

NOW THEREFORE, in consideration of the foregoing recitals, the following mutual covenants and conditions, and other good and valuable consideration, City and Contractor agree as follows:

T E R M S O F A G R E E M E N T :

1. **RECITALS.** City and Contractor hereby represent, warrant, and agree that the Recitals set forth above are true and correct and are incorporated herein by reference.
2. **CONTRACT DOCUMENTS.** The Contract Documents which comprise the entire understanding between City and Contractor shall only include: (a) this Agreement; (b) those documents listed in this section as Exhibits to this Agreement; (c) the City’s Solicitation for the Project and the quote submitted by Contractor in response to same (the “Solicitation Documents”); and (d) those documents identified in the Project Specifications section of this Agreement. Each of these documents are incorporated herein by reference for all purposes.

If there is a conflict between the terms of this Agreement and the Contract Documents, then the terms of this Agreement shall control, amend, and supersede any conflicting terms contained in the remaining Contract Documents.

A. **Exhibits to Agreement:** The Exhibits to this Agreement are as follows:

Exhibit A: Scope of Work (A-1 through A-8)

Exhibit B: Project Sign (B-1 through B-2)

Exhibit C: Plan Set (C-1)

If there is a conflict between the individual Exhibits regarding the scope of work to be performed, then any identified inconsistency shall be resolved by giving precedence in the following order: (1) Exhibit A, then (2) Exhibit B then (3) Exhibit C.

B. **Project Specifications:** In addition to the Contract Documents and up-to-date copies of shop drawings, this project will require the Contractor to have the following specifications and documents, which are incorporated by reference:

- i. **City of Ocala "Standard Specifications for Construction of Streets, Stormwater, Traffic, Water and Sewer Infrastructure"** available at:
<https://www.ocalafl.org/home/showdocument?id=20287>.
- ii. **Florida Department of Transportation ("FDOT") Standard Specifications for Road and Bridge Construction (latest edition)** available at:
<http://www.fdot.gov/programmanagement/Implemented/SpecBooks/>.

If there is a conflict between the individual Project Specifications regarding the scope of work to be performed, then any identified inconsistency shall be resolved by giving precedents to the most restrictive specification.

- 3. **SCOPE OF SERVICES.** Contractor shall provide all materials, labor, supervision, tools, accessories, equipment, permits, fees, testing, inspections, certifications, and all other things necessary for Contractor to perform its obligations under this Agreement as set forth in the attached **Exhibit A - Scope of Work** and the Solicitation Documents. Prime contractor must perform a minimum of sixty percent (60%) of the work with its own forces. The Scope of Work under this Agreement may only be adjusted by written amendment executed by both parties.
- 4. **COMPENSATION.** City shall pay Contractor a lump sum amount not to exceed **ONE HUNDRED THIRTY-EIGHT THOUSAND, THREE HUNDRED TWENTY-SEVEN AND 00/100 DOLLARS (\$138,327)** (the "Contract Sum") as full and complete compensation for the timely and satisfactory completion of the work in compliance with the pricing and other requirements set forth in the Contract Documents. A permit allowance has been established for this Project in the amount of **ONE THOUSAND FOUR HUNDRED AND NO/100 DOLLARS (\$1,400)** and is included in the Contract Sum. The pricing under this Agreement may only be adjusted by written amendment executed by both parties.
 - A. **Monthly Progress Payments:** The compensation amount under this section shall be paid by City, monthly, based upon a percentage of completion of the work as invoiced by Contractor and approved by City. The compensation sought under this Agreement is subject to the express terms of this Agreement and any applicable federal and/or state laws.
 - B. **Project Schedule and Progress Reports.** A progress report and updated project schedule must be submitted with each monthly pay request indicating the percent of services completed to date. This report will serve as support for payment to Contractor and the basis for payment in the event project is suspended or abandoned.
 - C. **Invoice Submission.** All invoices submitted by Contractor shall include the City Contract Number, an assigned Invoice Number, and an Invoice Date. Contractor shall submit a Certificate of Disbursement of Payment with each invoice after the first payment. Contractor shall also submit an updated schedule with each invoice. Contractor shall be provided with a cover sheet for invoicing. This cover sheet must be filled out correctly and submitted with each invoice. Contractor shall submit the original invoice through the responsible City Project Manager at: **City of Ocala Engineering Department, Capital Improvement Projects Division, Attn: Brian Hutchinson, 1805 NE 30th Avenue, Building 700, Ocala, Florida 34470**, E-Mail: whutchinson@ocalafl.org.
 - D. **Payment of Invoices by City.** The City Project Manager must review and approve all invoices prior to payment. City Project Manager's approval shall not be unreasonably withheld, conditioned, or delayed. Payments by City shall be made no later than the time periods established in section 218.735, Florida Statutes.

- E. **Retainage.** City shall withhold an amount equal to **FIVE PERCENT (5%)** of each monthly progress payment as retainage to secure Contractor's full and faithful performance of its obligations under this Agreement (the "Retainage"). Contractor shall not be entitled to any interest received by City on Retainage. The Retainage shall be payable to Contractor, subject to the provisions of this subsection, upon satisfaction of the following conditions precedent: (1) confirmation from the City Project Manager that Contractor has satisfactorily completed all work in accordance with the provisions of the Agreement; and (2) receipt of the Consent of Surety of the recorded bond for final payment.
 - F. **Withholding of Payment.** City reserves the right to withhold, in whole or in part, payment for any and all work that: (i) has not been completed by Contractor; (ii) is inadequate or defective and has not been remedied or resolved in a manner satisfactory to the City Project Manager; or (iii) which fails to comply with any term, condition, or other requirement under this Agreement. Any payment withheld shall be released and remitted to Contractor within **THIRTY (30)** calendar days of the Contractor's remedy or resolution of the inadequacy or defect.
 - G. **Excess Funds.** If due to mistake or any other reason Contractor receives payment under this Agreement in excess of what is provided for by the Agreement, Contractor shall promptly notify City upon discovery of the receipt of the overpayment. Any overpayment shall be refunded to City within **THIRTY (30)** days of Contractor's receipt of the overpayment or must also include interest calculated from the date of the overpayment at the interest rate for judgments at the highest rate as allowed by law.
 - H. **Tax Exemption.** City is exempt from all federal excise and state sales taxes (State of Florida Consumer's Certification of Exemption 85-8012621655C-9). The City's Employer Identification Number is 59-60000392. Contractor shall not be exempted from paying sales tax to its suppliers for materials to fulfill contractual obligations with the City, nor will Contractor be authorized to use City's Tax Exemption Number for securing materials listed herein.
5. **TIME FOR PERFORMANCE.** Time is of the essence with respect to the performance of all duties, obligations, and responsibilities set forth in this Agreement and the Contract Documents.
- A. Contractor shall mobilize and commence work no later than **SEVEN (7)** working days from the date of issuance of a Notice to Proceed for the project by City. At no time will the Contractor be allowed to lag behind.
 - B. **All work shall be substantially completed by Contractor in a manner satisfactory to the City Project Manager within NINETY (90) days of the start date indicated on the Notice to Proceed and ready for final payment within THIRTY (30) days of substantial completion.**
 - C. The Time for Performance under this Agreement may only be adjusted by Change Order, in the sole and absolute discretion of City. Any request for an extension of the Time for Performance must be submitted in a writing delivered to the City Project Manager, along with all supporting data, within **SEVEN (7)** calendar days of the occurrence of the event giving rise to the need for adjustment unless the City allows an additional period of time to ascertain more accurate data. All requests for adjustments in the Contract Time shall be determined by City.
 - D. **Weather Days:** Contractor shall submit a written request to the City Project (e-mail is the preferred method) for additional days for which work is suspended or delayed by weather. Weather days shall be reconciled with each monthly pay application for the time period which

the application is submitted and shall be final. Contractor performance and execution of work shall be considered in the determination for granting additional days.

- E. **Work Hours:** Normal working hours shall be Monday through Friday from 8:00 p.m. to 6:00 a.m. Work during the hours of 7:00 a.m. and 5:00 p.m. shall only be allowed within the median without lane closures. If additional working hours are necessary, Contractor must provide forty-eight (48) hours advance notice to the Project Manager and FDOT approval must be provided. Inspectors are not obligated to work on weekends. No work will be permitted on City-observed holidays.
 - F. As to any delay, inefficiency, or interference in this performance of this Agreement caused by any act or failure to act by City, the Contractor's sole remedy shall be the entitlement of an extension of time to complete the performance of the affected work in accordance with the Contract Documents. Contractor agrees to make no claim for extra or additional costs attributable to said delays, inefficiencies or interference, except as provided in this Agreement.
 - G. None of the provisions of this section shall exclude City's right of recovery for damages caused by delays or inefficiencies caused by any act or failure to act by Contractor, to include costs incurred by City for the procurement of additional professional services.
6. **LIQUIDATED DAMAGES FOR LATE COMPLETION.** The parties agree that it would be extremely difficult and impracticable under the presently known facts and anticipated circumstances to ascertain and fix the actual damages that City and its residents would incur should Contractor fail to achieve Substantial Completion and/or Final Completion and readiness for final payment by the dates specified for each under the terms of this Agreement. Accordingly, the parties agree that should Contractor fail to achieve Substantial Completion by the date specified, then Contractor shall pay City, as liquidated damages and not as a penalty, the sum of **EIGHT HUNDRED EIGHTY-TWO AND NO/100 DOLLARS (\$882)** per day for each calendar day of unexcused delay in achieving Substantial Completion beyond the date specified for Substantial Completion in the Contract Documents. After Substantial Completion, if Contractor shall neglect, refuse, or fail to complete the remaining work within the time specified in the Contract Documents for Final Completion and readiness for final payment or any proper extension thereof granted by City, Contractor shall pay City, as liquidated damages and not as a penalty, additional sum of **TWO HUNDRED AND NO/100 DOLLARS (\$200)** per day for each calendar day of unexcused delay in achieving completion and readiness for final payment.
- A. **No Waiver of Rights or Liabilities.** Permitting Contractor to continue and finish the work, or any part thereof, beyond the dates specified for Substantial Completion and/or Final Completion and readiness for final payment shall not operate as a waiver on the part of the City of any of its rights under this Agreement. Any liquidated damages assessed pursuant to this section shall not relieve Contractor from liability for any damages or costs of other contractors caused by a failure of Contractor to complete the work as agreed.
 - B. **Right to Withhold or Deduct Damages.** When liquidated damages are due and owing, City shall have the right to: (1) deduct the liquidated damages from any money in its hands or from any money otherwise due or to become due to Contractor; or to (2) initiate any applicable dispute resolution procedure for the recovery of liquidated damages within the times specified under this Agreement.
 - C. **Non-Cumulative.** The parties agree and understand that the amounts set forth under this section for liquidated damages are not cumulative with one another. The amount set forth

as liquidated damages for Contractor's failure to achieve Substantial Completion shall be assessed upon default and continue until Substantial Completion is attained. The amount set forth as liquidated damages for Contractor's failure to achieve Final Completion and readiness for payment shall be assessed after Substantial Completion is attained and apply until Final Completion is attained.

- D. **Additional Costs.** In addition to the liquidated damages set forth under this section, Contractor agrees to pay all costs and expenses incurred by City due to Contractor's delay in performance to include inspection fees, superintendence costs, and travel expenses.
 - E. **Injunctive Relief.** The parties acknowledge that monetary damages may not be a sufficient remedy for Contractor's failure to achieve Substantial Completion or Final Completion in accordance with the terms of this Agreement, and that City shall be entitled, in addition to all other rights or remedies in law and equity, to seek injunctive relief.
7. **DELAYS AND DAMAGES.** The Contractor agrees to make no claim for extra or additional costs attributable to any delays, inefficiencies, or interference in the performance of this contract occasioned by any act or omission to act by the City except as provided in the Agreement. The Contractor also agrees that any such delay, inefficiency, or interference shall be compensated for solely by an extension of time to complete the performance of the work in accordance with the provision in the standard specification.
 8. **MAINTENANCE AND GUARANTEE BOND.** Prior to final payment, Contractor shall furnish a Maintenance and Guarantee Bond in the amount of **TEN PERCENT (10%)** of the total project value, for a period of **THREE (3)** year for labor and **THREE (3)** year for materials from the date of final completion. Prior to the City's receipt of Contractor's fully executed Maintenance and Guarantee Bond, Contractor will warrant all labor and materials completed pursuant to this Agreement.
 9. **PUBLIC CONSTRUCTION BOND.** As required by section 255.05, Florida Statutes, Contractor shall furnish a certified and recorded Public Construction Bond in the amount of **ONE HUNDRED THIRTY-EIGHT THOUSAND, THREE HUNDRED TWENTY-SEVEN AND 00/100 DOLLARS (\$138,327)** as security for the faithful performance of the work as required and set forth in the Contract Documents within the time set forth for performance under this Agreement and for prompt payments to all persons defined in section 713.01, Florida Statutes, who furnish labor, services, or materials for the completion of the work provided for herein.
 10. **FORCE MAJEURE.** Neither party shall be liable for delay, damage, or failure in the performance of any obligation under this Agreement if such delay, damage, or failure is due to causes beyond its reasonable control, including without limitation: fire, flood, strikes and labor disputes, acts of war, acts of nature, terrorism, civil unrest, acts or delays in acting of the government of the United States or the several states, judicial orders, decrees or restrictions, or any other like reason which is beyond the control of the respective party ("Force Majeure"). The party affected by any event of force majeure shall use reasonable efforts to remedy, remove, or mitigate such event and the effects thereof with all reasonable dispatch.
 - A. The party affected by force majeure shall provide the other party with full particulars thereof including, but not limited to, the nature, details, and expected duration thereof, as soon as it becomes aware.
 - B. When force majeure circumstances arise, the parties shall negotiate in good faith any modifications of the terms of this Agreement that may be necessary or appropriate in order to arrive at an equitable solution. Contractor performance shall be extended for a number of days equal to the duration of the force majeure. Contractor shall be entitled to an extension

of time only and, in no event, shall Contractor be entitled to any increased costs, additional compensation, or damages of any type resulting from such force majeure delays.

11. **INSPECTION AND ACCEPTANCE OF THE WORK.** Contractor shall report its progress to the City Project Manager as set forth herein. All services, work, and materials provided by Contractor under this Agreement shall be provided to the satisfaction and approval of the Project Manager.
 - A. The Project Manager shall decide all questions regarding the quality, acceptability, and/or fitness of materials furnished, or workmanship performed, the rate of progress of the work, the interpretation of the plans and specifications, and the acceptable fulfillment of the Agreement, in his or her sole discretion, based upon both the requirements set forth by City and the information provided by Contractor in its Proposal. The authority vested in the Project Manager pursuant to this paragraph shall be confined to the direction or specification of what is to be performed under this Agreement and shall not extend to the actual execution of the work.
 - B. Neither the Project Manager's review of Contractor's work nor recommendations made by Project Manager pursuant to this Agreement will impose on Project Manager any responsibility to supervise, direct, or control Contractor's work in progress or for the means, methods, techniques, sequences, or procedures of construction or safety precautions or programs incident Contractor's furnishing and performing the work.
12. **TERMINATION AND DEFAULT.** Either party, upon determination that the other party has failed or refused to perform or is otherwise in breach of any obligation or provision under this Agreement or the Contract Document, may give written notice of default to the defaulting party in the manner specified for the giving of notices herein. Termination of this Agreement by either party for any reason shall have no effect upon the rights or duties accruing to the parties prior to termination.
 - A. **Termination by City for Cause.** City shall have the right to terminate this Agreement immediately, in whole or in part, upon the failure of Contractor to carry out any obligation, term, or condition of this Agreement. City's election to terminate the Agreement for default shall be communicated by providing Contractor written notice of termination in the manner specified for the giving of notices herein. Any notice of termination given to Contractor by City shall be effective immediately, unless otherwise provided therein, upon the occurrence of any one or more of the following events:
 - (1) Contractor fails to timely and properly perform any of the services set forth in the specifications of the Agreement;
 - (2) Contractor provides material that does not meet the specifications of the Agreement;
 - (3) Contractor fails to complete the work required within the time stipulated in the Agreement; or
 - (4) Contractor fails to make progress in the performance of the Agreement and/or gives City reason to believe that Contractor cannot or will not perform to the requirements of the Agreement
 - B. **Contractor's Opportunity to Cure Default.** City may, in its sole discretion, provide Contractor with an opportunity to cure the violations set forth in City's notice of default to Contractor. Contractor shall commence to cure the violations immediately and shall diligently and continuously prosecute such cure to completion within a reasonable time as determined by City. If the violations are not corrected within the time determined to be reasonable by City or to the reasonable satisfaction of City, City may, without further notice, declare

- Contractor to be in breach of this Agreement and pursue all remedies available at law or equity, to include termination of this Agreement without further notice.
- C. **City's Remedies Upon Contractor Default.** In the event that Contractor fails to cure any default under this Agreement within the time period specified in this section, City may pursue any remedies available at law or equity, including, without limitation, the following:
- (1) City shall be entitled to terminate this Agreement without further notice;
 - (2) City shall be entitled to hire another contractor to complete the required work in accordance with the needs of City;
 - (3) City shall be entitled to recover from Contractor all damages, costs, and attorney's fees arising from Contractor's default prior to termination; and
 - (4) City shall be entitled to recovery from Contractor any actual excess costs by: (i) deduction from any unpaid balances owed to Contractor; or (ii) any other remedy as provided by law.
- D. **Termination for Convenience.** City reserves the right to terminate this Agreement in whole or in part at any time for the convenience of City without penalty or recourse. The Project Manager shall provide written notice of the termination. Upon receipt of the notice, Contractor shall immediately discontinue all work as directed in the notice, notify all subcontractors of the effective date of the termination, and minimize all further costs to City including, but not limited to, the placing of any and all orders for materials, facilities, or supplies, in connection with its performance under this Agreement. Contractor shall be entitled to receive compensation solely for: (1) the actual cost of the work completed in conformity with this Agreement; and/or (2) such other costs incurred by Contractor as permitted under this Agreement and approved by City.
13. **WARRANTY.** Contractor warrants that all labor, materials, and equipment furnished under the agreement are new, of the type and quality required for the Project, and installed in a good and workmanlike manner in accordance with the Contract Documents. Contractor shall guarantee that the work shall be free from any defects in workmanship for a period of not less than **THREE (3)** years from the date of Final Completion. Contractor shall guarantee that the materials provided shall be free from any defects for the longer of: (1) **THREE (3)** years from the date of Final Completion; or (2) the period of warranty provided by any supplier or manufacturer. All written manufacturers' warranties for materials supplied must be provided to the City Project Manager before final payment will be authorized.
14. **PERFORMANCE EVALUATION.** At the end of the contract, City may evaluate Contractor's performance. Any such evaluation will become public record.
15. **NOTICE REGARDING FAILURE TO FULFILL AGREEMENT.** Any contractor who enters into an Agreement with the City of Ocala and fails to complete the contract term, for any reason, shall be subject to future bidding suspension for a period of **ONE (1)** year and bid debarment for a period of up to **THREE (3)** years for serious contract failures.
16. **CONTRACTOR REPRESENTATIONS.** Contractor expressly represents that:
- A. Contractor has read and is fully familiar with all the terms and conditions of this Agreement, the Contract Documents, and other related data and acknowledges that they are sufficient in scope and detail to indicate and convey understanding of all terms and conditions of the work to be performed by Contractor under this Agreement.

- B. Contractor has disclosed, in writing, all known conflicts, errors, inconsistencies, discrepancies, or omissions discovered by Contractor in the Contract Documents, and that the City's written resolution of same is acceptable to Contractor.
- C. Contractor has had an opportunity to visit, has visited, or has had an opportunity to examine and ask questions regarding the sites upon which the work is to be performed and is satisfied with the site conditions that may affect cost, progress, and performance of the work, as observable or determinable by Contractor's own investigation.
- D. Contractor is satisfied with the site conditions that may affect cost, progress, and performance of the work, as observable or determinable by Contractor's own investigation.
- E. Contractor is familiar with all local, state, and Federal laws, regulations, and ordinances which may affect cost, progress, or its performance under this Agreement whatsoever.
- F. **Public Entity Crimes.** Neither Contractor, its parent corporations, subsidiaries, members, shareholders, partners, officers, directors or executives, nor any of its affiliates, contractors, suppliers, subcontractors, or consultants under this Agreement have been placed on the convicted vendor list following a conviction of a public entity crime. Contractor understands that a "public entity crime" as defined in section 287.133(1)(g), Florida Statutes, is "a violation of any state or federal law by a person with respect to and directly related to the transaction of business with any public entity or with an agency or political subdivision of any other state or with the United States..." Contractor further understands that any person or affiliate who has been placed on the convicted vendor list following a conviction for a public entity crime: (1) may not submit a bid, proposal, or reply on a contract: (a) to provide any goods or services to a public entity; (b) for the construction or repair of a public building or public work; or (c) for leases of real property to a public entity; (2) may not be awarded or perform work as a contractor, supplier, subcontractor, or consultant under a contract with any public entity; and (3) may not transact business with any public entity in excess of the threshold amount provided in section 287.017, Florida Statutes, for CATEGORY TWO for a period of 36 months from the date of being placed on the convicted vendor list.

17. **CONTRACTOR RESPONSIBILITIES.** Except as otherwise specifically provided for in this Agreement, the following provisions are the responsibility of the Contractor:

- A. Contractor shall competently and efficiently supervise, inspect, and direct all work to be performed under this Agreement, devoting such attention thereto and applying such skills and expertise as may be necessary to perform the work in accordance with the Contract Documents.
- B. Contractor shall be solely responsible for the means, methods, techniques, sequences, or procedures of construction and safety precautions or programs incident thereto.
- C. Contractor shall be responsible to see that the finished work complies accurately with the contract and the intent thereof.
- D. Contractor shall comply with all local, state, and Federal laws, regulations, and ordinances which may affect cost, progress, or its performance under this Agreement, including, but not limited to obtaining all permits, licenses, and other authorizations necessary for the prosecution of the work and be responsible for all costs associated with same.
- E. Contractor shall operate and cause all construction equipment and materials supplied for or intended to be utilized in the Project to be operated and stored in only those areas prescribed by City. This includes the operations of workmen.
- F. Contractor shall be fully responsible for receipt, inspection, acceptance, handling, and storage of all construction equipment and materials supplied for or intended to be utilized in the

- Project, whether furnished by Contractor or City. Contractor shall be responsible for providing adequate safeguards to prevent loss, theft, damage, or commingling with other materials or projects.
- G. Contractor shall continue its performance under this Agreement during the pendency of any dispute or disagreement arising out of or relating to this Agreement, except as Contractor and City may otherwise agree in writing.
18. **NO EXCLUSIVITY.** It is expressly understood and agreed by the parties that this is not an exclusive agreement. Nothing in this Agreement shall be construed as creating any exclusive arrangement with Contractor or as prohibit City from either acquiring similar, equal, or like goods and/or services or from executing additional contracts with other entities or sources.
19. **RIGHT OF ACCESS AND OTHER WORK PERFORMED BY THIRD-PARTIES.** City may perform additional work related to the Project itself, or have additional work performed by utility service companies, or let other direct contracts therefore which shall contain General Conditions similar to these. Contractor shall afford the utility service companies and the other contractors who are parties to such direct contracts (or City, if City is performing the additional work with City's employees) reasonable opportunity for the introduction and storage of materials and equipment and the execution of work and shall properly connect and coordinate his work with theirs.
- A. If any part of Contractor's work depends for proper execution or results upon the work of any such other contractor or utility service company (or City), Contractor shall inspect and promptly report to City in writing any latent or apparent defects or deficiencies in such work that render it unsuitable for such proper execution and results. Contractor's failure to so report shall constitute an acceptance of the other work as fit and proper for integration with Contractor's work except for latent or non-apparent defects and deficiencies in the other work.
- B. Contractor shall do all cutting, fitting, and patching of work that may be required to make the parts come together properly and integrate with such other work. Contractor shall not endanger any work of others by cutting, excavating, or otherwise altering their work, and will only cut or alter their work with the written consent of City.
20. **STORAGE OF MATERIALS/EQUIPMENT.** Contractor shall be fully responsible for receipt, inspection, acceptance, handling, and storage of equipment and materials (whether furnished by Contractor or City) to be utilized in the performance of or incorporated into the work.
21. **RESPONSIBILITIES OF CITY.** City or its representative shall issue all communications to Contractor. City has the authority to request changes in the work in accordance with the terms of this Agreement and with the terms in **Exhibit A – Scope of Work.** City has the authority to stop work or to suspend any work.
22. **COMMERCIAL AUTO LIABILITY INSURANCE.** Contractor shall procure, maintain, and keep in full force, effect, and good standing for the life of this Agreement a policy of commercial auto liability insurance with a minimum combined single limit of One Million Dollars (\$1,000,000) per occurrence for bodily injury and property damage arising out of Contractor's operations and covering all owned, hired, scheduled, and non-owned automobiles utilized in said operations. If Contractor does not own vehicles, Contractor shall maintain coverage for hired and non-owned automobile liability, which may be satisfied by way of endorsement to Contractor's Commercial General Liability policy or separate Commercial Automobile Liability policy.
23. **COMMERCIAL GENERAL LIABILITY INSURANCE.** Contractor shall procure, maintain, and keep in full force, effect, and good standing for the life of this Agreement a policy of commercial general liability insurance with limits not less than:

- A. One Million Dollars (\$1,000,000) per occurrence and Two Million Dollars (\$5,000,000) aggregate (or project aggregate, if a construction project) for bodily injury, property damage, and personal and advertising injury; and
 - B. One Million Dollars (\$1,000,000) per occurrence and Two Million Dollars (\$5,000,000) aggregate (or project aggregate, if a construction project) for products and completed operations.
 - C. Policy must include coverage for contractual liability and independent contractors.
 - D. The City, a Florida municipal corporation, and its officials, employees, and volunteers as well as the Florida Department of Transportation are to be covered as additional insureds with a CG 20 26 04 13 Additional Insured – Designated Person or Organization Endorsement or similar endorsement providing equal or broader Additional Insured Coverage with respect to liabilities arising out of activities performed by or on behalf of Contractor. This coverage shall contain no special limitation on the scope of protection to be afforded to the City, its officials, employees, and volunteers.
24. **WORKERS' COMPENSATION AND EMPLOYER'S LIABILITY.** Contractor shall procure, maintain, and keep in full force, effect, and good standing for the life of this Agreement adequate workers' compensation and employer's liability insurance covering all of its employees in at least such amounts as required by Chapter 440, Florida Statutes, and all other state and federal workers' compensation laws, including the U.S. Longshore Harbor Workers' Act and the Jones Act, if applicable. Contractor shall similarly require any and all of its subcontractors to afford such coverage for all of its employees as required by applicable law. Contractor shall waive and shall ensure that Contractor's insurance carrier waives, all subrogation rights against the City of Ocala and its officers, employees, and volunteers for all losses or damages. Contractor's policy shall be endorsed with WC 00 03 13 Waiver of our Right to Recover from Others or its equivalent. **Exceptions and exemptions to this Section may be allowed at the discretion of the City's Risk Manager on a case-by-case basis in accordance with Florida Statutes and shall be evidenced by a separate waiver.**
25. **MISCELLANEOUS INSURANCE PROVISIONS.**
- A. Contractor's insurance coverage shall be primary insurance for all applicable policies. The limits of coverage under each policy maintained by Contractor shall not be interpreted as limiting Contractor's liability or obligations under this Agreement. City does not in any way represent that these types or amounts of insurance are sufficient or adequate enough to protect Contractor's interests or liabilities or to protect Contractor from claims that may arise out of or result from the negligent acts, errors, or omissions of Contractor, any of its agents or subcontractors, or for anyone whose negligent act(s) Contractor may be liable.
 - B. No insurance shall be provided by the City for Contractor under this Agreement and Contractor shall be fully and solely responsible for any costs or expenses incurred as a result of a coverage deductible, co-insurance penalty, or self-insured retention to include any loss not covered because of the operation of such deductible, co-insurance penalty, self-insured retention, or coverage exclusion or limitation.
 - C. Certificates of Insurance. No work shall be commenced by Contractor under this Agreement until the required Certificate of Insurance and endorsements have been provided nor shall Contractor allow any subcontractor to commence work until all similarly required certificates and endorsements of the subcontractor have also been provided. Work shall not continue after expiration (or cancellation) of the Certificate of Insurance and work shall not resume

- until a new Certificate of Insurance has been provided. **Contractor shall provide evidence of insurance in the form of a valid Certificate of Insurance (binders are unacceptable) prior to the start of work contemplated under this Agreement to: City of Ocala. Attention: Procurement & Contracting Department, Address: 110 SE Watula Avenue, Third Floor, Ocala Florida 34471, E-Mail: vendors@ocalafl.org.** Contractor's Certificate of Insurance and required endorsements shall be issued by an agency authorized to do business in the State of Florida with an A.M. Best Rating of A or better. The Certificate of Insurance shall indicate whether coverage is being provided under a claims-made or occurrence form. If any coverage is provided on a claims-made form, the Certificate of Insurance must show a retroactive date, which shall be the effective date of the initial contract or prior.
- D. City as an Additional Insured. The City of Ocala and the Florida Department of Transportation shall be named as an Additional Insured and Certificate Holder on all liability policies identified in this Section with the exception of Workers' Compensation and Professional Liability policies.
 - E. Notice of Cancellation of Insurance. Contractor's Certificate of Insurance shall provide **THIRTY (30) DAY** notice of cancellation, **TEN (10) DAY** notice if cancellation is for non-payment of premium. In the event that Contractor's insurer is unable to accommodate the cancellation notice requirement, it shall be the responsibility of Contractor to provide the proper notice. Such notification shall be in writing by registered mail, return receipt requested, and addressed to the certificate holder. Additional copies may be sent to the City of Ocala at vendors@ocalafl.org
 - F. Failure to Maintain Coverage. The insurance policies and coverages set forth above are required and providing proof of and maintaining insurance of the types and with such terms and limits set forth above is a material obligation of Contractor. Contractor's failure to obtain or maintain in full force and effect any insurance coverage required under this Agreement shall constitute material breach of this Agreement.
 - G. Severability of Interests. Contractor shall arrange for its liability insurance to include, or be endorsed to include, a severability of interests/cross-liability provision so that the "City of Ocala" (where named as an additional insured) will be treated as if a separate policy were in existence, but without increasing the policy limits.
26. **SAFETY/ENVIRONMENTAL.** Contractor shall be responsible for initiating, maintaining, and supervising all safety precautions and programs in connection with the Work. Contractor shall make an effort to detect hazardous conditions and shall take prompt action where necessary to avoid accident, injury or property damage. EPA, DEP, OSHA and all other applicable safety laws and ordinances shall be followed as well as American National Standards Institute Safety Standards. Contractor shall take all necessary precautions for the safety of, and shall provide the necessary protection to prevent damage, injury, or loss to:
- A. All employees on the work and other persons that may be affected thereby;
 - B. All work, materials and equipment to be incorporated therein, whether in storage on or off the site; and
 - C. Other property at the site or adjacent thereto, including trees, shrubs, lawns, walks, pavements, roadways, structures, and utilities not designated for removal, relocation, or replacement in the course of construction.

All, injury, or loss to any property caused, directly or indirectly, in whole or in part, by Contractor, any subcontractor, or anyone directly or indirectly employed by any of them, or anyone for whose acts any of them may be liable, shall be remedied by Contractor. Contractor's duties and responsibilities for the safety and protection of the work shall continue until such time as the work is completed and accepted by City.

27. **TRAFFIC CONTROL AND BARRICADES.** The Contractor shall mitigate impact on local traffic conditions to all extents possible. The Contractor is responsible for establishing and maintaining appropriate traffic control and barricades. The Contractor shall provide sufficient signing, flagging and barricading to ensure the safety of vehicular and pedestrian traffic at all locations where work is being done under this Agreement.
- A. In addition to the requirements set forth in bid, the Contractor shall maintain at all times a good and sufficient fence, railing or barrier around all exposed portions of said work in such a manner as to warn vehicular and pedestrian traffic of hazardous conditions.
 - B. Should Contractor fail to properly barricade his work or stored material sites in the manner outlined above, the City may have the necessary barricading done, and all cost incurred for said barricading shall be charged to the Contractor.
28. **WORK SITE AND CLEANUP.** Daily, during the progress of the work, Contractor shall keep the premises free from accumulations of waste materials, rubbish, and all other debris resulting from the work. At the completion of the work, Contractor shall remove all waste materials, rubbish, and debris from and about the premises, as well as all tools, appliances, construction equipment and machinery, and surplus materials, and shall leave the site clean and ready for occupancy by City. Contractor shall provide an inventory listing of all surplus materials in an area designated by City. Contractor shall restore to their original condition those portions of the site not designated or alteration by the Contract.
29. **CONSTRUCTION SURVEY LAYOUT.** The work to be performed pursuant to survey work provided by City shall be completed as necessary to establish all proper alignments, right of way, easements, benchmarks, elevations and grade stakes to complete all phases of this Contract.
- A. Contractor shall immediately bring to City's attention any survey issues that would impede the Contractor's completion of the work. The work performed pursuant to survey work at the Contractor's expense pursuant to this Agreement shall be prepared by a licensed surveyor and provided to the City. Any survey issues with these surveys that would impede the Contractor's completion of the work shall immediately be brought to the City's attention. If additional or corrective survey work is required, it shall be at Contractor's expense.
 - B. The City Engineer/City Project Manager shall establish a number of benchmarks on the project which in their opinion will enable the Contractor to perform the work. If Contractor shall remove or destroy any stake, marker or benchmark on the work without first having secured the approval of the City Engineer/City Project Manager, such stake, or benchmark shall be re-established by and at Contractor's expense.
 - C. It shall be the responsibility of Contractor to preserve all adjacent property corner markers which might be affected by their operations, and replace same if undermined. Corner locations known by City will be made available to Contractor. All original field notes, calculations, and other documents developed by the surveyor in conjunction with this work shall be given to City and become City property. All surveying work must be in accordance

with Chapters 177 and 472 of Florida Statutes and Chapter 61G17 of the Florida Administrative Code

30. **NON-DISCRIMINATORY EMPLOYMENT PRACTICES.** During the performance of the contract, the Contractor shall not discriminate against any employee or applicant for employment because of race, color, religion, ancestry, national origin, sex, pregnancy, age, disability, sexual orientation, gender identity, marital or domestic partner status, familial status, or veteran status and shall take affirmative action to ensure that an employee or applicant is afforded equal employment opportunities without discrimination. Such action shall be taken with reference to, but not limited to: recruitment, employment, termination, rates of pay or other forms of compensation and selection for training or retraining, including apprenticeship and on-the-job training.
31. **SUBCONTRACTORS.** Nothing in this Agreement shall be construed to create, impose, or give rise to any duty owed by City or its representatives to any subcontractor of Contractor or any other persons or organizations having a direct contract with Contractor, nor shall it create any obligation on the part of City or its representatives to pay or seek payment of any monies to any subcontractor of Contractor or any other persons or organizations having a direct contract with Contractor, except as may otherwise be required by law. City shall not be responsible for the acts or omissions of any Contractor, subcontractor, or of any of their agents or employees, nor shall it create any obligation on the part of City or its representatives to pay or to seek the payment of any monies to any subcontractor or other person or organization, except as may otherwise be required by law.
32. **EMERGENCIES.** In an emergency affecting the welfare and safety of life or property, Contractor, without special instruction or authorization from the City Project Manager, is hereby permitted, authorized and directed to act at its own discretion to prevent threatened loss or injury. Except in the case of an emergency requiring immediate remedial work, any work performed after regular working hours, on Saturdays, Sundays or legal holidays, shall be performed without additional expense to the City unless such work has been specifically requested and approved by the City Project Manager. Contractor shall be required to provide to the City Project Manager with the names, addresses and telephone numbers of those representatives who can be contacted at any time in case of emergency. Contractor's emergency representatives must be fully authorized and equipped to correct unsafe or excessively inconvenient conditions on short notice by City or public inspectors.
33. **INDEPENDENT CONTRACTOR STATUS.** Contractor acknowledges and agrees that under this Agreement, Contractor and any agent or employee of Contractor shall be deemed at all times to be an independent contractor and shall be wholly responsible for the manner in which it performs the services and work required under this Agreement. Neither Contractor nor its agents or employees shall represent or hold themselves out to be employees of City at any time. Neither Contractor nor its agents or employees shall have employee status with City. Nothing in this Agreement shall constitute or be construed to create any intent on the part of either party to create an agency relationship, partnership, employer-employee relationship, joint venture relationship, or any other relationship which would allow City to exercise control or discretion over the manner or methods employed by Contractor in its performance of its obligations under this Agreement.
34. **ACCESS TO FACILITIES.** City shall provide Contractor with access to all City facilities as is reasonably necessary for Contractor to perform its obligations under this Agreement.

35. **ASSIGNMENT.** Neither party may assign its rights or obligations under this Agreement to any third party without the prior express approval of the other party, which shall not be unreasonably withheld.
36. **RIGHT OF CITY TO TAKE OVER CONTRACT.** Should the work to be performed by Contractor under this Agreement be abandoned, or should Contractor become insolvent, or if Contractor shall assign or sublet the work to be performed hereunder without the written consent of City, the City Project Manager shall have the power and right to hire and acquire additional men and equipment, supply additional material, and perform such work as deemed necessary for the completion of this Agreement. Under these circumstances, all expenses and costs actually incurred by City to accomplish such completion shall be credited to City along with amounts attributable to any other elements of damage and certified by the Project Manager. The City Project Manager's certification as to the amount of such liability shall be final and conclusive.
37. **PUBLIC RECORDS.** The Contractor shall comply with all applicable provisions of the Florida Public Records Act, Chapter 119, Florida Statutes. Specifically, the Contractor shall:
- A. Keep and maintain public records required by the public agency to perform the service.
 - B. Upon request from the public agency's custodian of public records, provide the public agency with a copy of the requested records or allow the records to be inspected or copied within a reasonable time at a cost that does not exceed the cost provided in Chapter 119, Florida Statutes, or as otherwise provided by law.
 - C. Ensure that public records that are exempt or confidential and exempt from public records disclosure requirements are not disclosed except as authorized by law for the duration of the contract term and following completion of the contract if the Contractor does not transfer the records to the public agency.
 - D. Upon completion of the contract, transfer, at no cost, to the public agency all public records in possession of the Contractor or keep and maintain public records required by the public agency to perform the service. If the Contractor transfers all public records to the public agency upon completion of the contract, the Contractor shall destroy any duplicate public records that are exempt or confidential and exempt from public records disclosure requirements. If the Contractor keeps and maintains public records upon completion of the contract, the Contractor shall meet all applicable requirements for retaining public records. All records stored electronically must be provided to the public agency, upon request from the public agency's custodian of public records, in a format that is compatible with the information technology systems of the public agency.

IF THE CONTRACTOR HAS QUESTIONS REGARDING THE APPLICATION OF CHAPTER 119, FLORIDA STATUTES, TO THE CONTRACTOR'S DUTY TO PROVIDE PUBLIC RECORDS RELATING TO THIS CONTRACT, CONTACT THE CUSTODIAN OF PUBLIC RECORDS AT: CITY OF OCALA, OFFICE OF THE CITY CLERK; 352-629-8266; E-mail: clerk@ocalafl.org; City Hall, 110 SE Watula Avenue, Ocala, FL 34471.

38. **AUDIT.** Contractor shall comply and cooperate immediately with any inspections, reviews, investigations, or audits relating to this Agreement as deemed necessary by the Florida Office of the Inspector General, the City's Internal or External auditors or by any other Florida official with proper authority.

39. **PUBLICITY.** Contractor shall not use City's name, logo, seal or other likeness in any press release, marketing materials, or other public announcement without City's prior written approval.
40. **E-VERIFY.** Pursuant to section 448.095, Contractor shall register with and use the U.S. Department of Homeland Security's ("DHS") E-Verify System, accessible at <https://e-verify.uscis.gov/emp>, to verify the work authorization status of all newly hired employees. Contractor shall obtain affidavits from any and all subcontractors in accordance with paragraph 2(b) of section 448.095, Florida Statutes, and maintain copies of such affidavits for the duration of this Agreement. By entering into this Agreement, Contractor certifies and ensures that it utilizes and will continue to utilize the DHS E-Verify System for the duration of this Agreement and any subsequent renewals of same. Contractor understands that failure to comply with the requirements of this section shall result in the termination of this Agreement and Contractor may lose the ability to be awarded a public contract for a minimum of one (1) year after the date on which the Agreement was terminated. Contractor shall provide a copy of its DHS Memorandum of Understanding upon City's request. Please visit www.e-verify.gov for more information regarding the E-Verify System.
41. **CONFLICT OF INTEREST.** Contractor is required to have disclosed, with the submission of their bid, the name of any officer, director, or agent who may be employed by the City. Contractor shall further disclose the name of any City employee who owns, directly or indirectly, any interest in Contractor's business or any affiliated business entity. Any additional conflicts of interest that may occur during the contract term must be disclosed to the City of Ocala Procurement Department.
42. **WAIVER.** The failure or delay of any party at any time to require performance by another party of any provision of this Agreement, even if known, shall not affect the right of such party to require performance of that provision or to exercise any right, power or remedy hereunder. Any waiver by any party of any breach of any provision of this Agreement should not be construed as a waiver of any continuing or succeeding breach of such provision, a waiver of the provision itself, or a waiver of any right, power or remedy under this Agreement. No notice to or demand on any party in any circumstance shall, of itself, entitle such party to any other or further notice or demand in similar or other circumstances.
43. **SEVERABILITY OF ILLEGAL PROVISIONS.** Wherever possible, each provision of this Agreement shall be interpreted in such a manner as to be effective and valid under the applicable law. Should any portion of this Agreement be declared invalid for any reason, such declaration shall have no effect upon the remaining portions of this Agreement.
44. **INDEMNITY.** Contractor shall indemnify, defend, and hold harmless City and its elected officials, employees and volunteers and the State of Florida Department of Transportation (the "Department"), including the Department's officers, agents, and employees against any actions, claims, or damages arising out of, relating to, or resulting from negligent or wrongful acts of Contractor, or any of its officers, agents, or employees, acting within the scope of their office or employment, in connection with the rights granted to or exercised by Contractor.
45. **NO WAIVER OF SOVEREIGN IMMUNITY.** The foregoing indemnification shall not constitute a waiver of the Department's or City's sovereign immunity beyond the limits set forth in section 768.28, Florida Statutes. Nor shall the same be construed to constitute agreement by Contractor to indemnify City for the negligent acts or omissions of City, its officers, agents, or employees, or third parties. Nor shall the same be construed to constitute agreement by Contractor to indemnify the Department for the negligent acts or omissions of the Department, its officers,

agents, or employees, or third parties. This indemnification shall survive the termination of this Agreement.

46. **NOTICES.** All notices, certifications or communications required by this Agreement shall be given in writing and shall be deemed delivered when personally served, or when received if by facsimile transmission with a confirming copy mailed by registered or certified mail, postage prepaid, return receipt requested. Notices can be concurrently delivered by e-mail. All notices shall be addressed to the respective parties as follows:

If to Contractor: Blackwater Construction Services, LLC
Attention: Derek Dykes
2815 SE 30th Street
Ocala, Florida 34471
Phone: 352-372-7220
E-mail: derek@blackwatercsllc.com

If to City of Ocala: Daphne M. Robinson, Esq. - Contracting Officer
City of Ocala
110 SE Watula Avenue, Third Floor
Ocala, Florida 34471
Phone: 352-629-8343
E-mail: notices@ocalafl.org

Copy to: William E. Sexton, Esq., City Attorney
City of Ocala
110 SE Watula Avenue, Third Floor
Ocala, Florida 34471
Phone: 352-401-3972
E-mail: cityattorney@ocalafl.org

47. **ATTORNEYS' FEES.** If any civil action, arbitration or other legal proceeding is brought for the enforcement of this Agreement, or because of an alleged dispute, breach, default or misrepresentation in connection with any provision of this Agreement, the successful or prevailing party shall be entitled to recover reasonable attorneys' fees, sales and use taxes, court costs and all expenses reasonably incurred even if not taxable as court costs (including, without limitation, all such fees, taxes, costs and expenses incident to arbitration, appellate, bankruptcy and post-judgment proceedings), incurred in that civil action, arbitration or legal proceeding, in addition to any other relief to which such party or parties may be entitled. Attorneys' fees shall include, without limitation, paralegal fees, investigative fees, administrative costs, sales and use taxes and all other charges reasonably billed by the attorney to the prevailing party.
48. **JURY WAIVER.** IN ANY CIVIL ACTION, COUNTERCLAIM, OR PROCEEDING, WHETHER AT LAW OR IN EQUITY, WHICH ARISES OUT OF, CONCERNS, OR RELATES TO THIS AGREEMENT, ANY AND ALL TRANSACTIONS CONTEMPLATED HEREUNDER, THE PERFORMANCE HEREOF, OR THE RELATIONSHIP CREATED HEREBY, WHETHER SOUNDING IN CONTRACT, TORT, STRICT LIABILITY, OR OTHERWISE, TRIAL SHALL BE TO A COURT OF COMPETENT JURISDICTION AND NOT TO A JURY. EACH PARTY HEREBY IRREVOCABLY WAIVES ANY RIGHT IT MAY

HAVE TO A TRIAL BY JURY. NEITHER PARTY HAS MADE OR RELIED UPON ANY ORAL REPRESENTATIONS TO OR BY ANY OTHER PARTY REGARDING THE ENFORCEABILITY OF THIS PROVISION. EACH PARTY HAS READ AND UNDERSTANDS THE EFFECT OF THIS JURY WAIVER PROVISION.

49. **GOVERNING LAW.** This Agreement is and shall be deemed to be a contract entered and made pursuant to the laws of the state of Florida and shall in all respects be governed, construed, applied and enforced in accordance with the laws of the state of Florida.
50. **JURISDICTION AND VENUE.** The parties acknowledge that a majority of the negotiations, anticipated performance and execution of this Agreement occurred or shall occur in Marion County, Florida. Any civil action or legal proceeding arising out of or relating to this Agreement shall be brought only in the courts of record of the State of Florida in Marion County or the United States District Court, Middle District of Florida, Ocala Division. Each party consents to the exclusive jurisdiction of such court in any such civil action or legal proceeding and waives any objection to the laying of venue of any such civil action or legal proceeding in such court and/or the right to bring an action or proceeding in any other court. Service of any court paper may be effected on such party by mail, as provided in this Agreement, or in such other manner as may be provided under applicable laws, rules of procedures or local rules.
51. **REFERENCE TO PARTIES.** Each reference herein to the parties shall be deemed to include their successors, assigns, heirs, administrators, and legal representatives, all whom shall be bound by the provisions hereof.
52. **MUTUALITY OF NEGOTIATION.** Contractor and City acknowledge that this Agreement is a result of negotiations between Contractor and City, and the Agreement shall not be construed in favor of, or against, either party because of that party having been more involved in the drafting of the Agreement.
53. **SECTION HEADINGS.** The section headings herein are included for convenience only and shall not be deemed to be a part of this Agreement.
54. **RIGHTS OF THIRD PARTIES.** Nothing in this Agreement, whether express or implied, is intended to confer any rights or remedies under or because of this Agreement on any persons other than the parties hereto and their respective legal representatives, successors and permitted assigns. Nothing in this Agreement is intended to relieve or discharge the obligation or liability of any third persons to any party to this Agreement, nor shall any provision give any third persons any right of subrogation or action over or against any party to this Agreement.
55. **AMENDMENT.** No amendment to this Agreement shall be effective except those agreed to in writing and signed by both parties to this Agreement.
56. **COUNTERPARTS.** This Agreement may be executed in counterparts, each of which shall be an original and all of which shall constitute the same instrument.
57. **ELECTRONIC SIGNATURE(S).** Contractor, if and by offering an electronic signature in any form whatsoever, will accept and agree to be bound by said electronic signature to all terms and conditions of this Agreement. Further, a duplicate or copy of the Agreement that contains a duplicated or non-original signature will be treated the same as an original, signed copy of this original Agreement for all purposes.
58. **ENTIRE AGREEMENT.** This Agreement, including exhibits, (if any) constitutes the entire Agreement between the parties hereto with respect to the subject matter hereof. There are no

other representations, warranties, promises, agreements or understandings, oral, written or implied, among the Parties, except to the extent reference is made thereto in this Agreement. No course of prior dealings between the parties and no usage of trade shall be relevant or admissible to supplement, explain, or vary any of the terms of this Agreement. No representations, understandings, or agreements have been made or relied upon in the making of this Agreement other than those specifically set forth herein.

59. **LEGAL AUTHORITY.** Each person signing this Agreement on behalf of either party individually warrants that he or she has full legal power to execute this Agreement on behalf of the party for whom he or she is signing, and to bind and obligate such party with respect to all provisions contained in this Agreement.

IN WITNESS WHEREOF, the parties have executed this Agreement on 12 / 27 / 2022.

ATTEST:

CITY OF OCALA

Angel B. Jacobs

James P Hilty SR

Angel B. Jacobs
City Clerk

James P. Hilty, Sr.
City Council President

Approved as to form and legality:

BLACKWATER CONSTRUCTION SERVICES, LLC

William E. Sexton

Derek Dykes

William E. Sexton, Esq.
City Attorney

(Signature)

By: Blackwater Construction Services, LLC
(Printed Name)

Title: President
(Title of Authorized Signatory)

BACKGROUND

Contractors must provide all materials, labor, and equipment necessary to complete the construction of a two-unit restroom building at the Fort King National Historic Landmark located at 3925 E Fort King Street, Ocala, Florida.

The lump sum amount includes the complete construction of the restroom building at the Fort King National Historic Landmark as specified and designed by the City.

All work shall be coordinated through City Project Manager Brian Hutchinson, (352) 401-6935, e-mail: WHutchinson@ocalafl.org. Contractor must provide a valid telephone number and address to the City Project Manager. The phone must be answered during normal working hours, or voicemail must be available to leave a message.

PROJECT SPECIFICATIONS**Contractor will be responsible for the following:**

- Construct a new two-unit split block CMU restroom building with time-period façade on exterior walls and roof shingles as specified on the design plans.
- Installation of water and sewer lines and connection to nearest service as specified (all dimensions to be field verified by Contractor.)
- Installation of toilets. All toilets must be commercial grade with flush valves.
- Connection to electric as specified.
- Provision of erosion and sediment control as specified.
- Provision of tree protection for any trees within 50 feet of the building as specified.
- Minor site restoration including sod if disturbed, and any other site/utility concerns which may affect construction.
- Trenching conduits/pipe, minor grading and sodding disturbed areas.
- Provide and install chain link construction fence around the perimeter of the construction area.
- Time period façade needs to be like the one on the fort.
- The only duct work needed is for the exhaust fan.
- Shake shingles must be cedar.
- Ceilings and walls must be epoxy paint.
- Moisture mitigation must be provided.
- Cypress siding must be sealed but not stained.

Cover base around the wall must be epoxy, and the transition from wall to floor must be seamless.

CITY RESPONSIBILITIES

- The City shall provide and transport required fill dirt material to the construction site. Contractor will be responsible for all grading and compaction.
- **Sidewalks** – City (Parks Staff) will install sidewalks to new building. Any damage to existing sidewalks during construction will be the Contractor's responsibility for repair.
- **Survey** – City (Survey Staff) to provide updated survey and stake new building location.
- Replacement of any existing sidewalk sections, if necessary, to be performed by City.
- Removal and replacement of existing landscaping and irrigation on project site by City.

WORKING HOURS

Standard working hours for this work will be from 7:00 a.m. to 5:00 p.m., Monday through Friday, excluding City-observed holidays. Any work outside of these hours must be approved in writing by the City Project Manager prior to the work being performed.

PERMITS

1. **Permits Required:** Contractor will be responsible for obtaining the following City of Ocala permits at no additional cost to the City:
 - Electrical
 - Plumbing
 - Building
 - And any other permits for the completion of this building.

Contractor shall be responsible for pulling all permits. **The permit allowance is \$1,400 for this project.**

CONSTRUCTION TIMEFRAME

1. **Construction Time:** Contractor agrees that the Work will be substantially completed within **Ninety (90)** days of issued Notice to Proceed (NTP), and completed and ready for final payment within thirty (30) days after substantial completion.
 - A. Contractor agrees that this project will be completed in the time agreed upon between the City and the Contractor. The Contractor agrees to commence work on the date specified in a written "Notice to Proceed" by the City. Such "Notice to Proceed" will be issued at the pre-construction conference.
 - B. The Contractor must be able to mobilize and begin construction no later seven (10) days of NTP date. At no time will the Contractor be allowed to lag behind.
 - C. The Contractor shall complete the projects within the time limit specified in the "Notice to Proceed." The Contractor is responsible for accurately tracking contract time and construction progress.
 - D. Contractor shall submit updated progress schedules with all pay applications. Unsubstantiated delays and/or consistent failure to meet progress schedules will be cause for the City to terminate the contract.

2. **Weather Days:** Contractor shall submit a written request to the City Project Manager (e-mail is the preferred method) for additional days for which work is suspended or delayed by weather.
 - A. Weather days shall be reconciled with each monthly pay application for the time period which the application is submitted and shall be final.
 - B. Contractor performance and execution of work will be considered in the determination for granting additional days.

SUB-CONTRACTORS

The prime contractor must perform a minimum of 30% of the work with its own forces.

CODES

Contractor must follow all current building codes.

CONTRACT INFORMATION

- Instructions to Contractor and governing specifications for this project are in City of Ocala, "Standard Specifications for Construction", and can be found at the following website:
<https://www.ocalafl.org/home/showpublisheddocument/20007/637793834655670000>
In case of dispute, FDOT or Building Code Standard Specifications for Road and Bridge Construction, latest edition, take precedence on construction items including concrete, earthwork, Maintenance of Traffic (MOT), sediment control. Information on these items found at link: <https://www.fdot.gov/programmanagement/Implemented/SpecBooks/>
- Change in Scope - Should the City and Contractor mutually agree to a change in the scope of services being provided during the term of this agreement, a mutually agreed to price adjustment will be allowed.

CONSTRUCTION COMPONENT SCOPE

1. Supply and install erosion control silt fence, tree protection fencing and perimeter security fencing in accordance with City guidelines City of Ocala, "Standard Specifications for Construction" and can be found at the following website
<https://www.ocalafl.org/home/showpublisheddocument/20007/637793834655670000>
and NPDES requirements.
2. Provide a construction layout survey and a detailed "as built" survey at final completion locating and labeling size of all new electrical conduits, concrete junction boxes and all other information required for "as built" survey.
3. Provide one (1) project sign as per detail in appendix, secure in locations determined by project manager for duration of the project.

ELECTRICAL

Electrical work shall comply with all applicable codes as enforced by the authorities having jurisdiction, including (but not limited to) NFPA 70 National Electric Code and NFPA 101 Life Safety Codes.

Contractor will be responsible for installing electric service, piping and wire from new restroom to existing volt/meter. Contractor to coordinate with OEU when accessing volt/meter to assist with safety protocols.

CODES AND WARRANTY

Contractor shall be responsible for all product warranties. Contractor must provide written manufacturers' warranties to the City Project Manager, and Recreation and Parks Department before final payment will be authorized. Contractor shall follow all current building codes.

SAFETY

The Contractor shall be fully responsible for meeting all OSHA, local, state, and national codes concerning safety provisions for their employees, sub-contractors, all building and site occupants, staff, public, etc. Contractor shall be responsible for all damage to buildings, curbing, pavement, landscaping or irrigation systems caused by the delivery or removal of materials. In no event shall the City be responsible for any damages to any of the Contractor's equipment or clothing lost, damaged, destroyed, or stolen. Prior to completion, storage and adequate protection of all material and equipment will be the Contractor's responsibility.

CONTRACTOR CAPABILITY AND REFERENCE

Contractor may be required to show that it has the necessary staffing, equipment, ability and financial resources to perform the work specified in a satisfactory manner and within the time specified.

CONTRACTOR AND PERSONNEL

Contractor shall utilize competent employees in performing the work. At the request of the City, the Contractor shall replace any incompetent, unfaithful, abusive or disorderly person in his or her employ. The City and the Contractor shall each be promptly notified by the other of any complaints received. Contractor personnel shall abide by the City's smoking regulations. Smoking is restricted to designated smoking areas only and is not permitted in any City buildings. All Contractor's and sub-contractor's vehicles shall display their company name located on the side and all personnel shall be required to wear a company shirt. Contractor shall coordinate services with the City Project Manager.

CLEANUP

At completion of work, Contractor shall remove from the building and site: all tools, equipment surplus materials, debris, temporary facilities, and equipment. The areas of work shall be swept thoroughly and all marks, stains, rust, dirt, paint drippings, and the like shall be removed from all new and existing work, to the satisfaction of the City. Removal and disposal of old equipment and material shall be Contractor's responsibility. Contractor shall dispose of debris, equipment, and material in a legal manner.

DENSITY AND CONCRETE TESTING

Contractor is responsible for density testing. Backfilling and compaction procedures shall be performed in accordance with City of Ocala Specification 31 23 23.00, and the FDOT Standard Specifications for Road and Bridge Construction (Latest Edition) and FDOT Design standards (Latest Edition), or as otherwise directed in writing by the City of Ocala.

CONSTRUCTION SURVEY LAYOUT

1. The work to be performed shall be for the survey work necessary to establish proper alignments, right of way, easements, benchmarks, elevations and grade stakes to complete all phases of this Contract as specified.
2. It shall be the responsibility of the Contractor to preserve all adjacent property corner markers which might be affected by their operations and replace same if undermined. Corner locations known by the City will be made available to the Contractor.
3. All original field notes, calculations, and other documents developed by the surveyor in conjunction with this work shall be given to the City and become City property.
4. The above work shall be done in such sequence that the above items will be in place at final acceptance of the project. All surveying work must be in accordance with Chapters 177 and 472 of Florida Statutes and Chapter 61G17 of the Florida Administrative Code.
5. Payment for this work shall be full compensation for all labor, material; equipment and other incidental costs incurred by Contractor to obtain completed and approved construction.

CONSTRUCTION FACILITIES**Administrative Submittals:**

1. Submit copies of permits and approvals for Construction as required by laws and regulations and governing agencies.
2. Submit temporary construction parking area plans, storage yard, storage trailer location, staging area plan, and plan for disposal of waste materials.
3. Submit material submittals (3 copies) to Project Manager for items in scope of work to be approved before order and installation.

MOBILIZATION

1. Obtaining of required permits and the moving of Contractor's operations and equipment required for construction.
2. Provide on-site construction power and wiring, and on-site communication facilities as needed.
3. Provide on-site sanitary facilities and potable water facilities as specified and as required by governing agencies. The Contractor will not be permitted to use the City sanitary facilities during construction.
4. Posting of OSHA required Notices and establishing of safety programs and procedures.

CLEANING DURING CONSTRUCTION

Provide approved containers for collection and disposal of waste materials, debris, and rubbish. At least once weekly dispose of such waste materials, debris, and rubbish off-site.

FINAL CLEANING**At completion of work, clean entire work and project site as applicable.**

1. Leave the work and adjacent areas affected in a cleaned condition satisfactory to the City.

2. Remove grease, dirt, dust, paint, stains, labels, fingerprints, and other foreign materials from exposed surfaces.
3. Hose clean sidewalks and concrete exposed surfaces.
4. Use only cleaning materials recommended by manufacturer of surfaces to be cleaned.

In case of dispute, FDOT Standard Specifications for Road and Bridge Construction, latest edition, take precedence on construction items including concrete, earthwork, maintenance of traffic (MOT), and sediment control. Information on these items found at link: <https://www.fdot.gov/programmanagement/Implemented/SpecBooks/>

STANDARD SPECIFICATIONS FOR SITE WORK

- Requirements for this project are to return the site to original condition or to new grades as shown on the project drawings. Standard general site work requirements are found in Sections 120, 125 and 162 of FDOT Standard Specifications for Road and Bridge Construction, latest edition.
- City of Ocala "Standard Specifications for Construction of Streets, Stormwater, Traffic, Water and Sewer Infrastructure" available at:
<https://www.ocalafl.org/home/showpublisheddocument/20007/637793834655670000>
- Florida Department of Transportation (FDOT) Standard Specifications for Road and Bridge Construction (January 2019) available at:
<http://www.fdot.gov/programmanagement/Implemented/SpecBooks/>
- FDOT Design Standards can be obtained from:
<http://www.fdot.gov/roadway/DS/18/STDs.shtm>

Contractor must have the above specifications and documents, in addition to up-to-date copies of Contract documents, shop drawings and plans for each individual project, at the project site always.

EROSION, SEDIMENT, AND FLOOD CONTROL

1. Provide, maintain, and operate temporary facilities to control erosion and sediment, and to protect work and existing facilities from flooding during construction.
2. Maintain drainage ways and construct temporary drainage facilities to allow runoff to flow properly.

FINISH GRADING

As soon as practical after completion of backfilling, the Contractor shall grade all areas on the site to be grassed, as indicated on drawings, or disturbed by the construction operations and acceptable to the City.

GRASSING

1. The Contractor shall sod areas disturbed by construction activities with Bahia sod. Existing sod shall be removed by Contractor and areas graded as required to have sod meet new and existing elevations.
2. It is the intent of this specification that the Contractor shall produce a satisfactory stand of grass, free of weeds and foreign growth, before final payment. If it is necessary to repeat any or all of the work, including plowing, fertilizing, watering, and sodding, the Contractor shall nevertheless repeat these operations without additional compensation until a satisfactory stand is obtained.

3. Contractor shall be responsible to see that planted areas receive enough water until full coverage is obtained.
4. All planting, fertilizing and preparations for providing a healthy stand of grass shall be done in accordance with Section 570 of FDOT Standard Specifications for Road and Bridge Construction, latest edition.

PROJECT SIGNAGE

Prior to the start of construction, the Contractor shall provide one (1) four (4') feet high by four (4') feet wide project sign. The location shall be approved by the City's Inspector in the field. Signage information shall include City/Contractor/architect information (See appendix for project sign drawings), sign information and colors shall match the detail. Contractor shall verify names of Council members and Mayor before lettering sign.

SIGN MATERIALS

1. Main signage boards: 3/4" marine plywood mounted on a 2" x 4" wood frame, painted on all sides.
2. Lettering: Shall be black intermediate grade vinyl or an approved equal.
3. Border Lines: Shall be black a minimum of 1/2" wide, inset 1" from the board edge.
4. Top & Bottom Warning Panels: Shall be 6" retro-reflective "orange" pavement marking tape (Reference MUTCD Section 1A.12 "color code")

SUBSTANTIAL COMPLETION

1. When the Contractor considers the work as substantially complete, the Contractor shall submit to the City:
 - A. A written notice that the work or designated portion thereof, is substantially complete.
 - B. A list of items to be completed or corrected.
2. Within a reasonable time after receipt of such notice, the City will inspect to determine the status of completion.
3. Should the City determine that the work is not substantially complete:
 - A. The City will promptly notify the Contractor in writing, giving the reasons therefore.
 - B. The Contractor shall remedy the deficiencies in the work and send a second written notice of substantial completion to the City.
 - C. The City will re-inspect the work.
4. When the City finds that the work is substantially complete, the City shall prepare a Certificate of Substantial Completion with a list of items to be completed or corrected before final payment. (Punch List)

FINAL INSPECTION

1. When the Contractor considers the work complete, the Contractor shall submit written certification that:
 - A. Contract documents have been reviewed.

- B. Work has been inspected for compliance with contract documents.
 - C. Work has been completed in accordance with contract documents.
 - D. Equipment and systems have been tested in the presence of the City representative and are operational.
2. The City will inspect to verify the status of completion with reasonable promptness after receipt of such certification.
 3. Should the City consider that the work is incomplete or defective:
 - A. The City will promptly notify the Contractor in writing, listing the incomplete or defective work.
 - B. The Contractor shall take immediate steps to remedy the stated deficiencies and send a second written certification to the City that the work is complete.
 - C. The City will re-inspect the work.
 4. When the City finds that the work is acceptable under the contract documents, the City shall request the Contractor make closeout submittals. (As Built Plans).

CONTRACTOR'S CLOSEOUT SUBMITTALS TO THE CITY

1. Evidence of compliance with requirements of governing authorities.
2. Consent of surety to final payment.
3. Approved project record documents and a hard copy "As Built".
4. Completion of all submittals as required by Contract documents.
5. Warranties and operational manuals (2 copies)

FINAL APPLICATION FOR PAYMENT

Contractor shall submit the final application for payment in accordance with the procedures and requirements stated in the scope of work and general conditions.



YOUR TAXES AT WORK....

**City of Ocala Fort King National
Historic Landmark Restrooms**

PROJECT ITB # CIP/220747
CITY OF OCALA, FLORIDA

CITY COUNCIL:

BARRY MANSFIELD
DISTRICT 1

IRE BETHEA, SR
(COUNCIL PRESIDENT)
DISTRICT 2

JAY MUSLEH
DISTRICT 3

KRISTEN DREYER
DISTRICT 4

JAMES HILTY
(COUNCIL PRESIDENT PRO-TEM)
DISTRICT 5

KENT GUINN
MAYOR

CITY OF OCALA

**CAPITAL IMPROVEMENT
PROJECTS DIVISION**

CONTRACTOR
(enter contractor, tbd)

PROJECT COST
(enter amount, tbd)

START DATE
(month day, year tbd)

COMPLETION DATE
(month day, year tbd)

**FOR PROJECT INFORMATION CONTACT:
CAPITAL IMPROVEMENT PROJECTS DIVISION**

352-629-8419

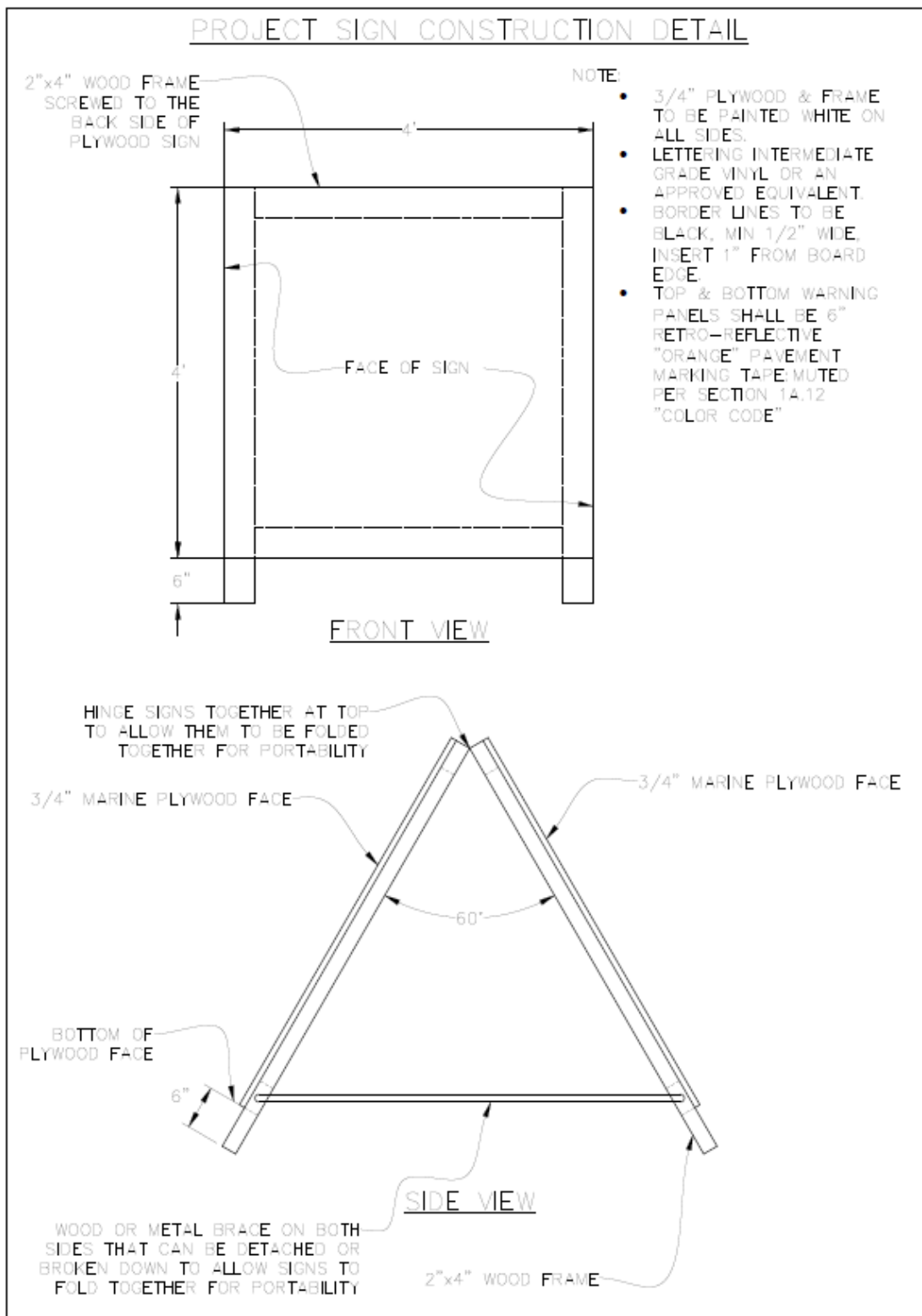

**The Plan Set for this project, dated June 7, 2022
is available for inspection and copying at
1805 NE 30th Avenue, Building 700, Ocala, Florida 34470.**

Title	FOR SIGNATURES - Construction Services Agreement for Fort.....
File name	FOR COUNCIL - Con...ooms - Blackw.pdf
Document ID	0b8be62378aa1635d3ac1f353cfdec7fd6227d84
Audit trail date format	MM / DD / YYYY
Status	● Signed

Document History



SENT

12 / 21 / 2022

13:13:31 UTC-5

Sent for signature to William E. Sexton (ws Sexton@ocalafl.org), Blackwater Construction Services, LLC (derek@blackwatercslc.com), James P. Hilty, Sr. (jhilty@ocalafl.org) and Angel Jacobs (ajacobs@ocalafl.org) from biverson@ocalafl.org
IP: 216.255.240.104



VIEWED

12 / 27 / 2022

11:18:20 UTC-5

Viewed by William E. Sexton (ws Sexton@ocalafl.org)
IP: 216.255.240.104



SIGNED

12 / 27 / 2022

11:22:56 UTC-5

Signed by William E. Sexton (ws Sexton@ocalafl.org)
IP: 216.255.240.104



VIEWED

12 / 27 / 2022

13:36:10 UTC-5

Viewed by Blackwater Construction Services, LLC (derek@blackwatercslc.com)
IP: 24.250.225.143

Title	FOR SIGNATURES - Construction Services Agreement for Fort.....
File name	FOR COUNCIL - Con...ooms - Blackw.pdf
Document ID	0b8be62378aa1635d3ac1f353cfdec7fd6227d84
Audit trail date format	MM / DD / YYYY
Status	● Signed

Document History



12 / 27 / 2022
13:37:51 UTC-5

Signed by Blackwater Construction Services, LLC
(derek@blackwatercslc.com)
IP: 24.250.225.143



12 / 27 / 2022
14:08:51 UTC-5

Viewed by James P. Hilty, Sr. (jhilty@ocalafl.org)
IP: 174.211.235.198



12 / 27 / 2022
14:09:14 UTC-5

Signed by James P. Hilty, Sr. (jhilty@ocalafl.org)
IP: 174.211.235.198



12 / 28 / 2022
08:14:39 UTC-5

Viewed by Angel Jacobs (ajacobs@ocalafl.org)
IP: 98.180.28.209



12 / 28 / 2022
08:14:51 UTC-5

Signed by Angel Jacobs (ajacobs@ocalafl.org)
IP: 98.180.28.209



12 / 28 / 2022
08:14:51 UTC-5

The document has been completed.